



# INSTRUCTION MANUAL

## Polypropylene Chemical Storage Cabinet



### SAFELAB SYSTEMS

Airone Building • 8 Beaufighter Road • Weston-Super-Mare • BS24 8EE  
Telephone: 01934 421340 • Fax: 01934 641569 • E-mail: [Safelab@safelab.co.uk](mailto:Safelab@safelab.co.uk)  
[WWW.SAFELAB.CO.UK](http://WWW.SAFELAB.CO.UK)

DOCUMENT NO: M32 ISSUE NO: 04 ISSUE DATE: 01/11/2015



## Contents

Page 2	Contents
Page 3	Foreword.
Page 4	Principles of Operation.
Page 5	Installation, and Assembly Instructions.
Page 6	Specification.
Page 7	Key To Component Parts.
Page 8	Operating Instructions.
Page 9	Wiring Diagram.
Page 10	Calibration.
Page 11	Maintenance.
Page 11	Cleaning.
Page 12	Pre-filter Replacement
Page 12	Main Filter Replacement
Page 13	Spare Parts
Page 14	CE Declaration of Conformity



## **FOREWORD**

This manual has been prepared to give guidance in the use of the Polypropylene Chemical Storage Cabinet.

This manual contains the information required to ensure optimum operation of both 1.0Mtr. & 1.2Mtr. Polypropylene Chemical Storage Cabinet.

It is recommended that service and maintenance operations should only be undertaken by SAFELAB Service Engineers or their authorised agents.

Details of Service Contracts/Programmes, along with information on these and other products are available on request from:

### **SAFELAB SYSTEMS LTD.**

**Airone Building  
8 Beaufighter Road  
Weston-Super-Mare  
BS24 8EE**

Telephone - 01934 421340  
Fax - 01934 641569  
E-mail - safelab@safelab.co.uk  
  
Website: - <http://www.safelab.co.uk>

### **NOTE:**

**This Chemical Storage Cabinet requires annual service and inspection under the requirements of COSHH regulation 9 by a suitably qualified engineer.**



## PRINCIPLES OF OPERATION

Air is drawn into the cabinet through the holes in bottom of the front door **A** at a velocity high enough to ensure entrainment of any fumes/odours given off by the contents of the cabinet. Fumes/odours from the chemicals in the cabinet **B** are carried by the moving body of air into the filter housing above the chamber where it passes through the pre-filter **C** and main filter **D** to remove vapours and other noxious fumes/odours before being expelled by the exhaust fan **E** as clean air **F**.

The fan **E**, which is mounted on top of the main filter, exerts a negative pressure on the internal space within the cabinet **B**. This in turn pulls external air into the cabinet through the air-intake holes in the bottom of the door and keeps a constant circulation of air passing over the items placed inside the cabinet whilst ensuring that fumes and noxious odours are trapped and adsorbed by the main filter. A reed switch **G** mounted at the top of the door increases the fan speed to ensure continual removal of fumes/odours when the door is opened.

Note: To ensure correct operation, door must remain closed at all times.

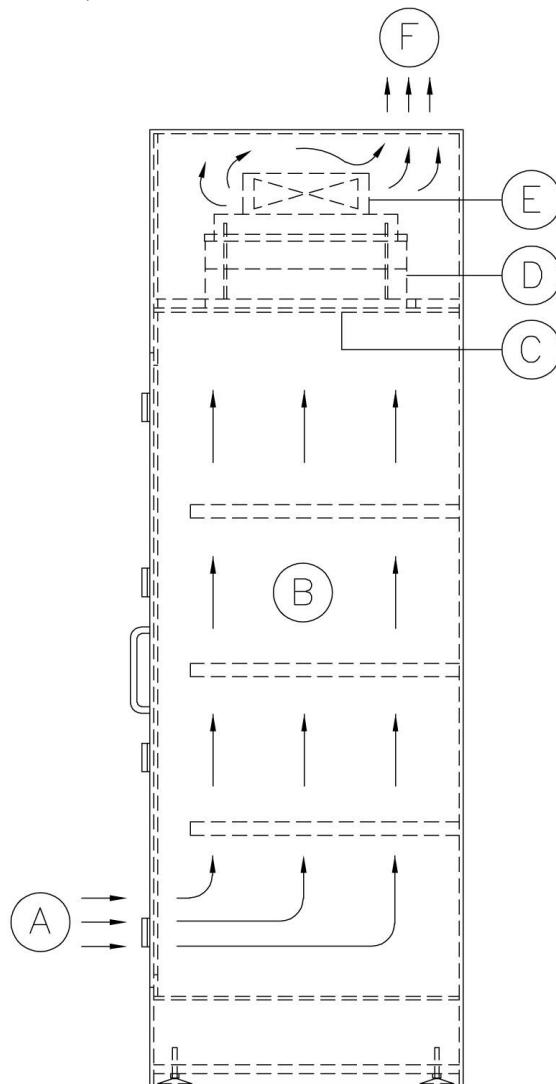



## INSTALLATION AND ASSEMBLY INSTRUCTIONS

### Contents of Packaging (as standard):

- Pre-filter.
- Main filter.
- Safety Log Book.
- Operational manual.
- Mains power lead.
- Quality Pass.
- Service and Maintenance Letter.
- Locking vice latch key.
- Conformity certificates.
- Warranty form.

1. Remove outer packaging.
2. Remove main filter front cover panel by removing the 8 countersunk screws, to expose the main filter housing.
3. Unpack the main filter and prepare suitable equipment for its safe handling and installation.  
Slide the filter gasket side down between the support guides in the filter chamber.  
Use the four thumbscrews on the filter/fan plenum to evenly clamp the filter in position.
4. Fill in the date on the filter identification label and stick it on the front of the filter ensuring it will be clearly visible through the window in the front of the access panel.
5. Replace the front cover panel.
6. Open the door, and from inside the cabinet at the top, rotate tag and drop down the pre-filter clamping frame. Locate the pre-filter and refit frame.
7. Following this procedure it is recommended that the filter monitoring procedure detailed in the Operational Safety Manual is performed. This ensures correct seating of the filter within the cabinet.  
**Written records of filter monitoring are a legal requirement under COSHH.**
8. Connect to the power supply and the cabinet is ready for commissioning by a suitably qualified person.

### Note:

Space for free air circulation must be provided at the top and front of the cabinet. Allowances should be made for regular air changes in the vicinity of the cabinet. Avoid blocking of air inlets and outlets.



## SPECIFICATION

Definition:	The Safelab Chemical Storage Cabinet is designed to absorb odours given off by stored chemicals. A list for correct filter selection is available on request from Safelab Systems.	
Application:	Wherever the working environment needs to be protected from noxious odours given off by the contents of stored chemicals.	
Construction:	Freestanding floor mounted polypropylene structure with clear PVC door, plastic hinges, fittings and locking catch.	
Air Intake:	Holes in lower area of the clear PVC door allow air to be drawn into the cabinet.	
Filter Housing:	Located above the cabinet, this contains the main filter (to customers specification) and the exhaust fan.	
Low Airflow light:	Red, gives a visual indication of a low airflow condition or when the pre-filter or main filter needs changing. Located on the top RH side of the cabinet.	
ON/OFF Switch:	Illuminated green and located on the right hand side of the cabinet below red low airflow light.	
Door Switch:	A reed switch activated by the door increases the fan speed when door is opened to help maintain the continued removal of fumes/odours.	
Hour Counter:	Displays total running time.	
Supply:	230V 50Hz. 1PH.	
Noise Levels:	Minimal = 56db.	
Shelves:	Removable perforated polypropylene shelves (3 off).	
Dimensions:	External:	1.0Mtr. = 1000x2140x700mm (WxHxD) 1.2Mtr. = 1200x2140x700mm (WxHxD)
	Internal (chamber):	1.0Mtr. = 975x1530x675mm (WxHxD) 1.2Mtr. = 1175x1530x675mm (WxHxD)



## KEY TO COMPONENT PARTS

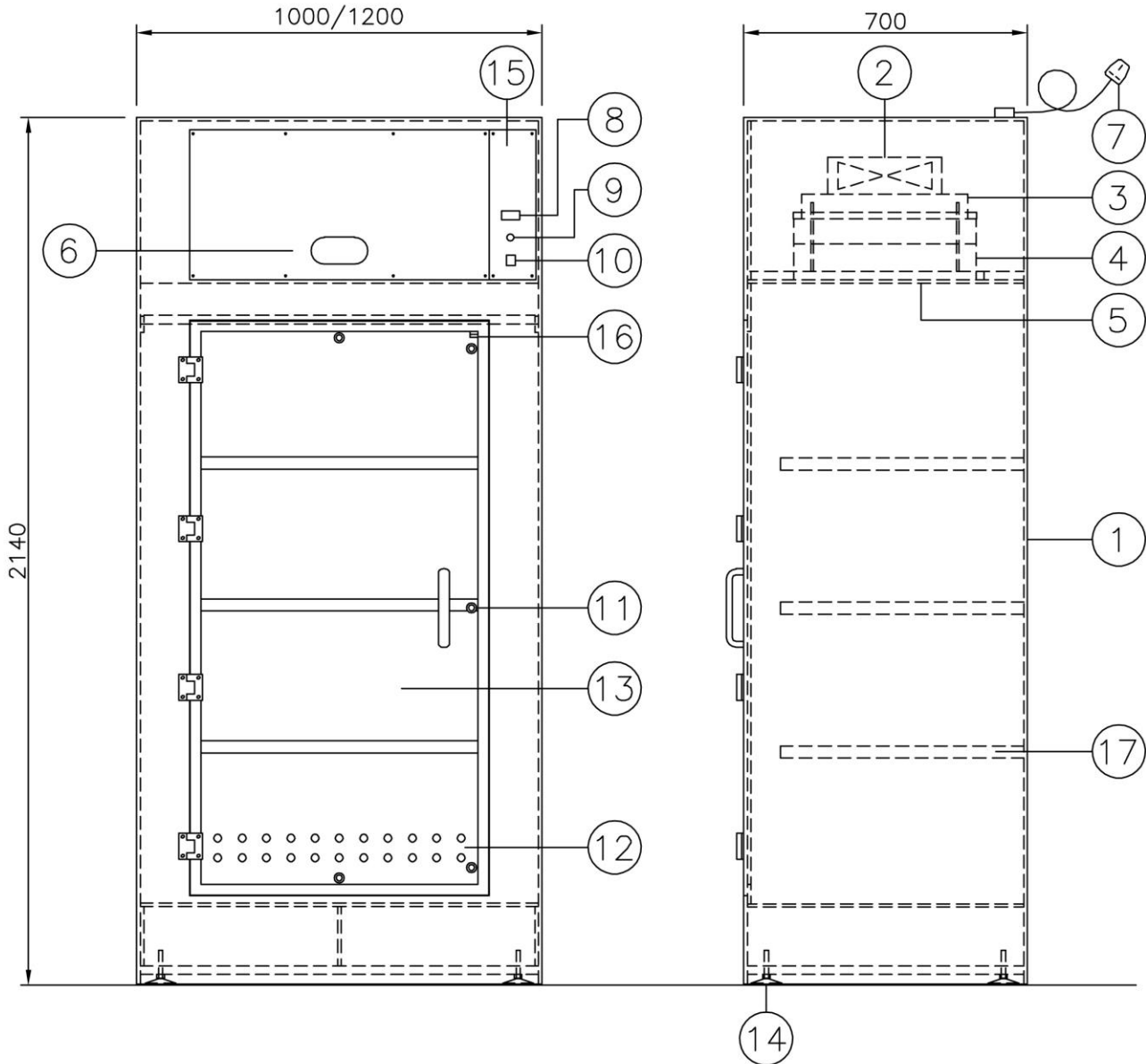

- |  |  |
|--|--|
| 1) White polypropylene body.           | 10) Illuminating ON/OFF switch (green).  |
| 2) Exhaust fan.                        | 11) Door catches (1 lockable).           |
| 3) Plenum.                             | 12) Air inlet perforations.              |
| 4) Main filter.                        | 13) Clear PVC door.                      |
| 5) Filtrete pre-filter.                | 14) Adjustable levelling feet.           |
| 6) Filter access panel/viewing window. | 15) Electrical access panel.             |
| 7) Mains lead with moulded plug.       | 16) Door operated fan speed switch.      |
| 8) Hour counter.                       | 17) Removable perforated shelves (3 off) |
| 9) Low airflow warning light (red).    |  |



## **OPERATING INSTRUCTIONS**

(ENSURE THE CABINET IS PLUGGED INTO THE MAINS ELECTRICAL SUPPLY)

1. Switch on unit using the **ON/OFF** switch on the top RH side of the cabinet. The red warning light should go out as the fan runs up to normal running speed.
2. Rotate vice latches anticlockwise to open door (1 with key provided).
3. Place the items required to be stored on the shelves.
4. Close the door and engage all of the vice latches (1 with key provided).
7. Keep the unit permanently switched **ON** when storing items in the cabinet.
9. Fill in the **SAFELAB** Operational Safety Log Book after use.

**Note: Safelab Systems recommend regular visual inspection of the pre-filter.**





# WIRING DIAGRAM

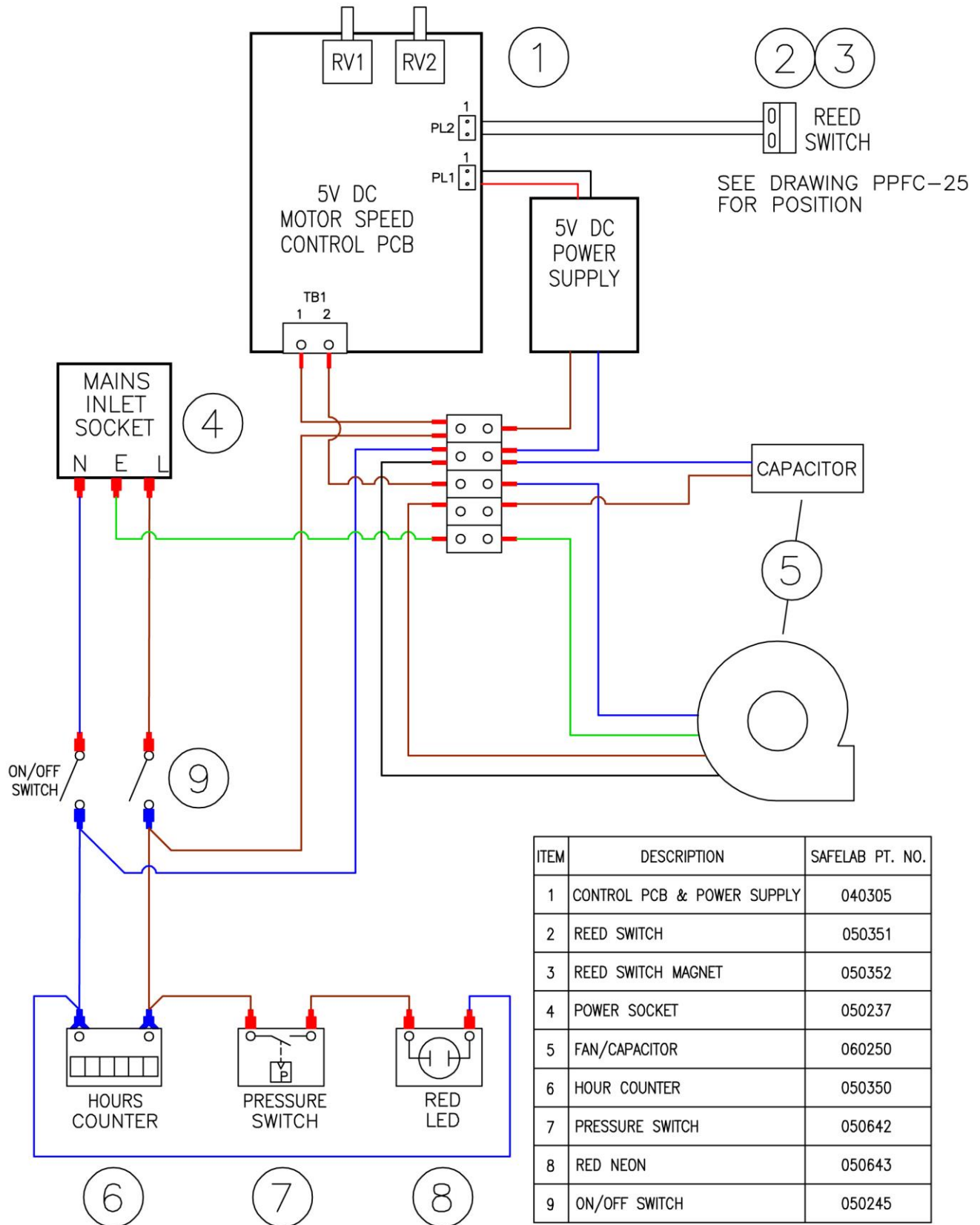

ITEM	DESCRIPTION	SAFELAB PT. NO.
1	CONTROL PCB & POWER SUPPLY	040305
2	REED SWITCH	050351
3	REED SWITCH MAGNET	050352
4	POWER SOCKET	050237
5	FAN/CAPACITOR	060250
6	HOUR COUNTER	050350
7	PRESSURE SWITCH	050642
8	RED NEON	050643
9	ON/OFF SWITCH	050245



## CALIBRATION

(SHOULD ONLY BE UNDERTAKEN BY A SUITABLY QUALIFIED PERSON)

1. Remove four screws and withdraw the electrical panel at front right hand side of unit far enough to give access to the pressure switch adjuster screw and fan speed adjustment potentiometers RV1 & RV2 (see photo).

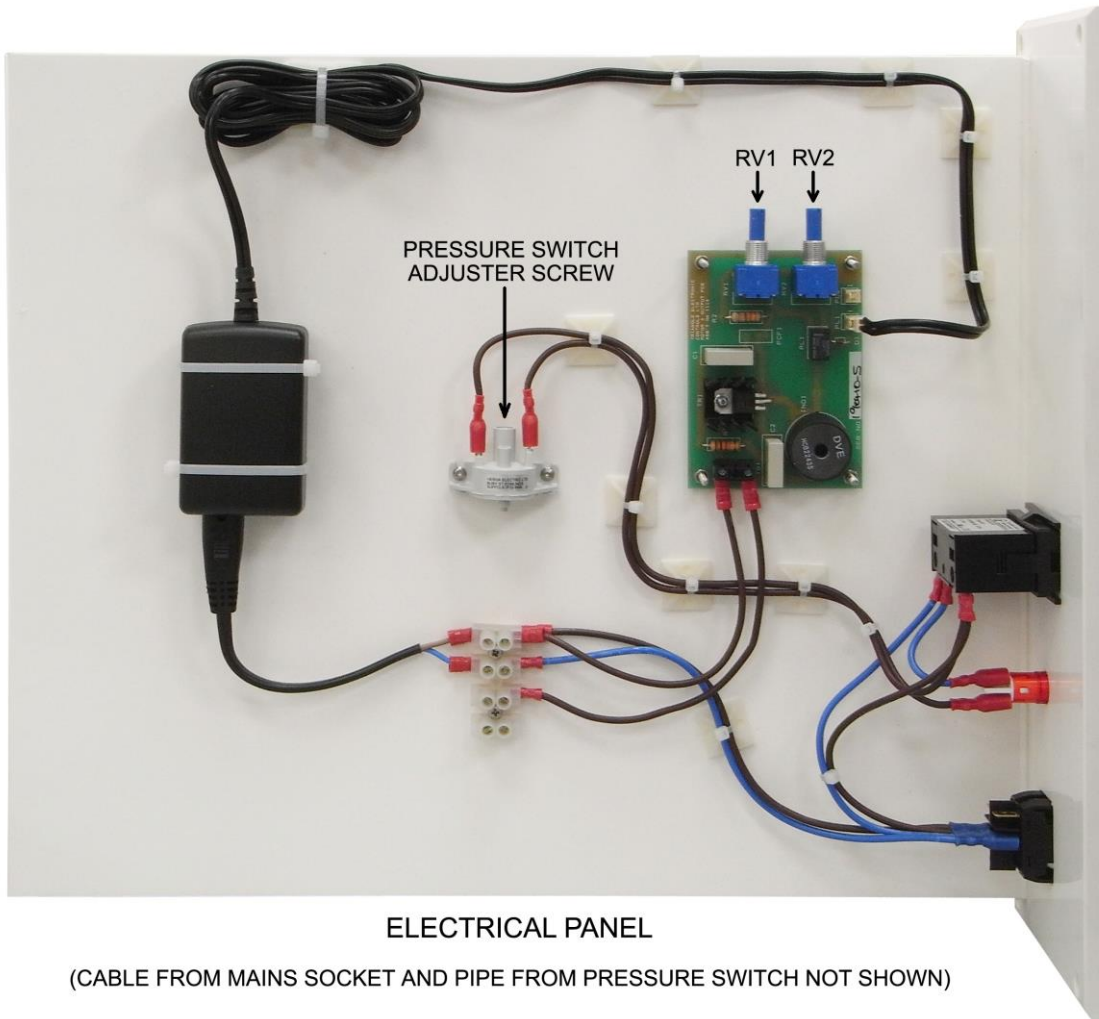

2. Switch on unit. Ensure door is shut. Measure airflow at 50mm from lower door air intake perforations and adjust RV2 to obtain inlet airflow of 0.4m/s using a 100mm diameter calibrated vane anemometer.
3. Cover holes at bottom of front door. If red light comes on, rotate pressure switch screw anticlockwise until it goes out, then slowly rotate the pressure switch screw clockwise until the red LED just comes on.
4. Remove cover from holes in door.
5. Open door and set RV1 to give maximum fan speed.
6. Refit the electrical panel.



## MAINTENANCE

Your Polypropylene Chemical Storage Cabinet should have an annual service and inspection by a suitably qualified person, to maintain its good working condition, ensure correct operation and reduce the possibility of hazard to the operator.

We recommend that a service programme is arranged with **Safelab Systems Ltd.**

**Regular maintenance by our qualified personnel will ensure safe running of your equipment and will ensure that you meet your requirements under COSHH regulation 9.**

## CLEANING

- The materials used to construct the Polypropylene Chemical Storage Cabinet have been selected to give maximum durability and a long life. It is beneficial however to regularly clean the internal and external surfaces.
- It is recommended that the cabinet is switched on during any cleaning procedure and that suitable protective clothing (face-mask, gloves and safety glasses) are worn.
- Surfaces, door and perforated shelves should be cleaned with a mild detergent solution, followed by wiping down with a damp cloth then wiped dry.



## **FILTER REPLACEMENT**

DURING THE PRE-FILTER AND MAIN FILTER REPLACEMENT PROCEDURE, SUITABLE PROTECTIVE CLOTHING (FACE-MASK, GLOVES AND SAFETY GLASSES) MUST BE WORN

### **PRE-FILTER REPLACEMENT**

1. With the cabinet switched on, open the front door.
2. Remove all items from the top shelf. All hazardous substances should be removed and stored in a suitable place during the replacement procedure.
3. From inside the cabinet at the top, rotate tag, drop down the pre-filter clamping frame a little and remove pre-filter by folding the front edge away from you so that it's folded in half, withdraw it, then place and seal it directly into a plastic bag for disposal.
4. Locate new pre-filter on the filter frame, raise into position and rotate the retaining tag to secure it in place.
5. Replace the contents of the cabinet and close the front door.
6. Enter details of pre-filter change in the Safety Log Book.

### **MAIN FILTER REPLACEMENT**

1. Switch off the cabinet and disconnect it from the mains electricity supply.
2. Remove the main filter cover panel (eight countersunk screws) to expose the main filter housing.
3. Unscrew the four knurled knobs inside the main filter housing that clamp the fan and plenum assembly on top of the filter. Four springs lift the assembly clear of the main filter as these are released.
4. Unpack the Main filter and prepare suitable equipment for its safe handling. Place the filter gasket side upwards on a clean flat surface (Retain the packaging for disposing of the old filter).
5. **Before removing the main filter please note it weighs approx. 15kg and may require two people to safely remove it from the housing.**  
Firmly grip each side of the main filter, push up to break seal, and withdraw it from the filter housing.
6. Use the packaging that was retained from the new filter to place over the old filter for safe disposal.
7. With the gasket side downwards, slide the new filter into place between the guides in the main filter housing ensuring that it's located fully to the back stop and evenly retighten the four knurled knobs to clamp the fan and filter assembly above the main filter. Lower pre-filter panel and inspect gasket seating of the main filter.
8. Fill in the date on the filter identification label and stick it on the front of the filter ensuring it will be clearly visible through the window in the front of the access panel.
9. Replace the main filter front cover panel.
10. Reconnect to the mains electricity supply and switch on the cabinet.
11. Enter details of main filter change in the Safety Log Book.
12. Following this procedure it is recommended that the filter monitoring procedure detailed in the Operational Safety Manual is performed. This ensures correct seating of the filter within the cabinet.  
**Written records of filter monitoring are a legal requirement under COSHH.**



## SPARE PARTS

Main Filter: See identification label on front of filter.

Pre-filter: Part No. 111088 (pack of 12)

Key: Part No. 130206

Mains lead: Part No. 050201