



INSTRUCTION MANUAL

Polypropylene Forensic Drying Cabinet



SAFELAB SYSTEMS

Airone Building • 8 Beaufighter Road • Weston-Super-Mare • BS24 8EE
Telephone: 01934 421340 • Fax: 01934 641569 • E-mail: Safelab@safelab.co.uk
WWW.SAFELAB.CO.UK



Contents

| | |
|----------------|--|
| Page 2 | Contents. |
| Page 3 | Foreword. |
| Page 4 | Principles of Operation. |
| Page 5 | Installation & Assembly Instructions. |
| Page 6 | Specification. |
| Page 7 | Specification Diagram. |
| Page 8 | Operating Instructions. |
| Page 9 | Wiring Diagram. |
| Page 10 | Calibration. |
| Page 11 | Maintenance. |
| Page 11 | Cleaning. |
| Page 12 | Box Pre-filter Replacement. |
| Page 12 | Pre-filter Replacement. |
| Page 13 | Main Filter Replacement. |
| Page 14 | Spare parts |
| Page 15 | CE Declaration of Conformity |



FOREWORD

This manual has been prepared to give guidance in the use of the Polypropylene Forensic Drying Cabinet.

This manual contains the information required to ensure optimum operation of both 1.0Mtr. & 1.2Mtr. Polypropylene Forensic Drying Cabinets.

It is recommended that service and maintenance operations should only be undertaken by SAFELAB Service Engineers or their authorised agents.

Details of Service Contracts/Programmes, along with information on these and other products are available on request from:

SAFELAB SYSTEMS LTD
Airone Building
Beaufighter Road
Weston-Super-Mare
BS24 8EE

Telephone - 01934 421340
Fax - 01934 641569
E-mail - safelab@safelab.co.uk

Website: - <http://www.safelab.co.uk>

NOTE:

This Forensic Drying Cabinet requires annual service and inspection under the requirements of COSHH regulation 9 by a suitably qualified engineer.



PRINCIPLES OF OPERATION

Air is drawn into the cabinet through the air-intake box pre-filter **A** (in the air-intake housing), removing dust and other particulates as it passes through the pre-filter.

Contaminants from the articles in the cabinet are carried by the moving body of air into the filter housing above the cabinet **B** where it passes through the pre-filter **C** and main filter/s **D** to remove bacteria and other sub micron particulates, vapours and other noxious fumes/odours before being expelled by the exhaust fan **E** as clean air **F**.

The fan **E**, which is mounted on top of the main filter/s exerts a negative pressure on the internal space within the cabinet **B**. This in turn pulls external air into the cabinet through the air-intake pre-filter **A** and keeps a constant circulation of pre-filtered clean air passing over the articles placed inside the cabinet whilst ensuring that noxious odours and bacteria are trapped and adsorbed by the main filter/s.

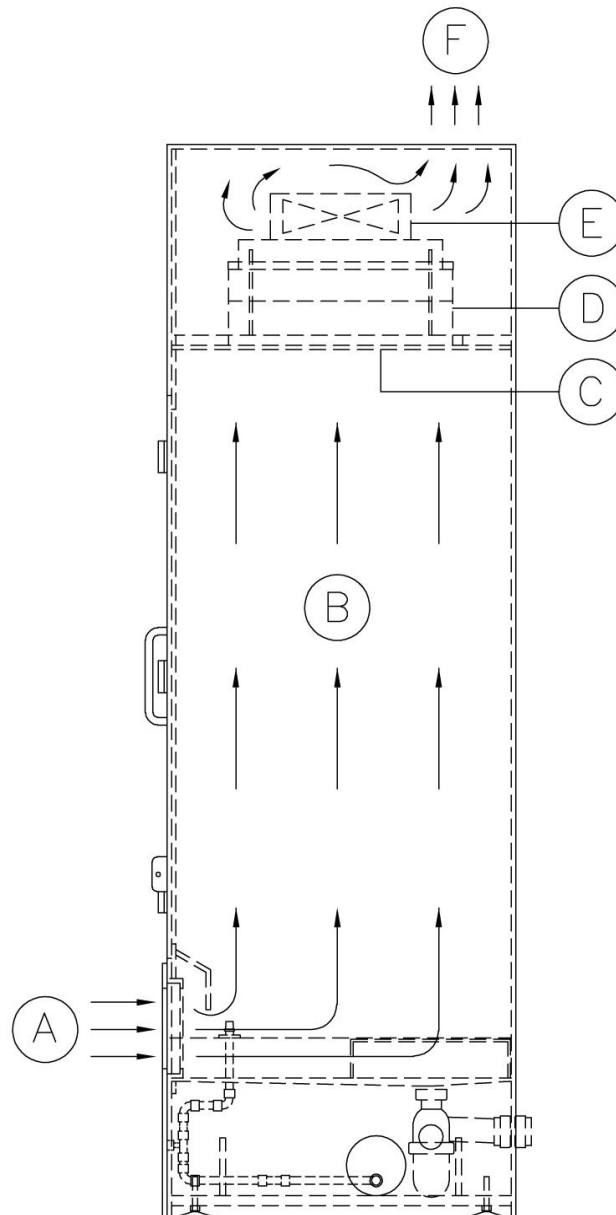



INSTALLATION AND ASSEMBLY INSTRUCTIONS

Contents of Packaging (as standard):

- Pre-filter.
- Box pre-filter.
- Main filter/s
- Shower handset with flexible hose and hozelock fitting.
- Safety Log Book.
- Mains power lead.
- Operational manual
- Quality Pass.
- Service and Maintenance Letter.
- Locking vice latch key
- Conformity certificates
- Warranty form.

1. Remove outer packaging.
2. Remove main filter front cover panel by removing the 8 countersunk screws, to expose the main filter housing.
3. Unpack the Main filter/s and prepare suitable equipment for their safe handling and installation. Slide the filter/s gasket side down between the support guides in the filter chamber (the HEPA filter is the lower filter). Use the four thumbscrews on the filter/fan plenum to evenly clamp the filter in position.
4. Fill in the date on the filter identification label and stick it on the front of the filter ensuring it will be clearly visible through the window in the front of the access panel.
5. Replace the front cover panel.
6. Open the door and from inside the cabinet at top, rotate tag and drop down the pre-filter clamping frame. Locate the pre-filter and refit frame.
7. Following this procedure, it is recommended that the filter monitoring procedure detailed in the Operational Safety Manual is performed. This ensures correct seating of the filter/s within the cabinet. **Written records of filter monitoring are a legal requirement under COSHH.**
8. Connect to the power supply and the cabinet is ready for commissioning. See **Calibration** instructions on page 10.

Note: Space for free air circulation must be provided at the top and front of the cabinet. Allowances should be made for regular air changes in the vicinity of the cabinet. Avoid blocking of air inlets and outlets.

Plumbing

A hand shower hose is supplied with a Hozelock connection. There is a Hozelock fitting inside the cabinet for this, and a mains water isolator valve at the bottom of the cabinet. The shower is not designed to take full mains pressure permanently and should be isolated at the valve (access hole at bottom right) when not in use.

Waste

A 38mm Vulcathene bottle trap is fitted to the waste outlet. The waste outlet pipe can exit from the left, right, or rear of the cabinet.



SPECIFICATION

| | |
|--------------------|--|
| Definition: | The SAFELAB Polypropylene Forensic Drying Cabinet is designed for drying evidence (articles of clothing etc), when placed inside the cabinet whilst protecting them from particulate contamination and dust. The cabinet also protects the operator and surrounding environment from noxious odours and other contaminants which may be given off by the contents of the cabinet. |
| Application: | Wherever the working environment needs to be protected from noxious odours and other contaminants given off by the contents of the cabinet and where those contents need to be kept in a clean well ventilated environment free from particulate contaminants. |
| Construction: | Freestanding floor mounted polypropylene structure with clear PVC door, plastic hinges and fittings. |
| Air-intake: | A polypropylene panel on the front of the cabinet retains the inlet box pre-filter and also provides access to the waste bottle trap if required. |
| Filter Housing: | Located above the cabinet, this contains the main filter/s and exhaust fan. |
| Low Airflow Light: | Red, gives a visual indication of a low airflow condition or when the pre-filter or main filter/s need changing. Located on the top RH side of the cabinet. |
| ON/OFF Switch: | Illuminated green, and located on the right hand side of the cabinet below the red low airflow light |
| Door Switch: | A reed switch activated by the door reduces the fan speed when door is opened to prevent a sudden inrush of unfiltered air. |
| Hour Counter: | Displays total running time. |
| Supply: | 230V 50Hz. 1PH. |
| Noise Levels: | Minimal = 56db. |
| Services: | Shower handset with trigger handle and flexible shower hose for wash down. Waste outlet with anti-siphon bottle trap fitted to drain. |
| Hanging Rail: | Horizontal PVC hanging rail for coat hangers. |
| Perforated Stand: | A removable perforated polypropylene stand is supplied for use inside the cabinet which allows wash down from shower and other liquids to naturally flow down to dished drain waste below. |
| Dimensions: | External: 1Mtr. = 1000x2140x700mm (WxHxD) 1.2Mtr. = 1200x2140x700mm (WxHxD) Internal (chamber): 1Mtr. = 975x1430x670mm (WxHxD) 1.2Mtr.= 1175x1430x670mm (WxHxD) |



SPECIFICATION DIAGRAM

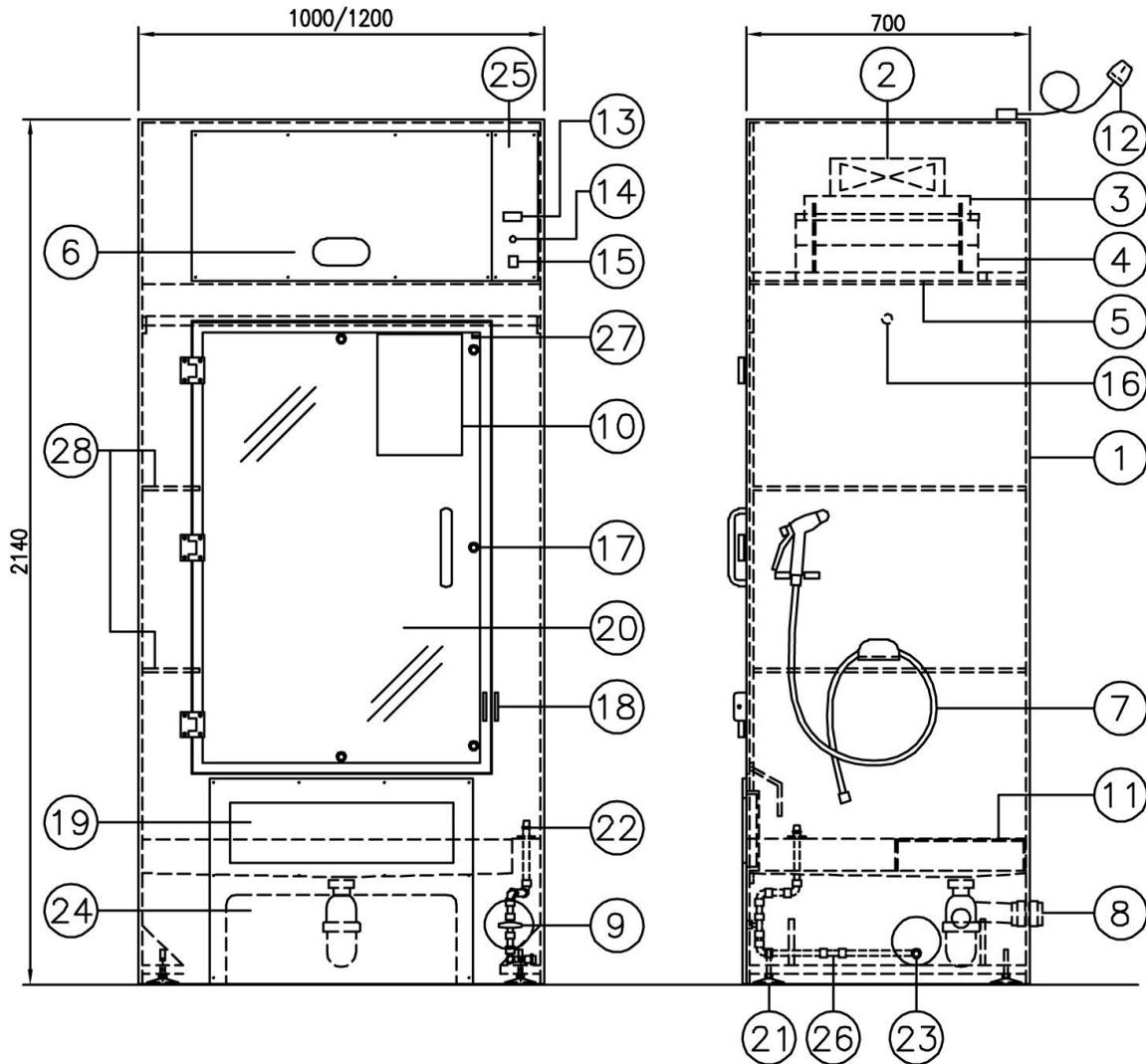

- | | |
|--|--|
| 1) White polypropylene body. | 14) Low airflow warning light (red). |
| 2) Exhaust fan. | 15) Illuminating ON/OFF switch (green). |
| 3) Plenum. | 16) Hanging rail. |
| 4) Main filter/s. | 17) Door catches (1 lockable). |
| 5) Pre-filter. | 18) Security tag location lugs. |
| 6) Filter access panel/viewing window. | 19) Inlet box pre-filter. |
| 7) Shower handset with trigger on handle and flexible shower hose. | 20) Clear PVC door. |
| 8) Vulcathene bottle trap. (can exit on left, right, or rear). | 21) Adjustable levelling feet. |
| 9) Water isolation valve. | 22) Internal fitting for shower hose. |
| 10) Note board. | 23) Male 3/4" BSP fitting for water inlet. |
| 11) Removable perforated stand. | 24) Access panel (pre-filter/drain). |
| 12) Mains lead with moulded plug. | 25) Electrical access panel. |
| 13) Hour counter. | 26) Double check valve. |
| | 27) Door operated fan speed switch. |
| | 28) Perforated shelves |



OPERATING INSTRUCTIONS

(ENSURE THE CABINET IS PLUGGED INTO THE MAINS ELECTRICAL SUPPLY)

1. Switch on unit using the **ON/OFF** switch on the top RH side of the cabinet. The red warning light should go out as the fan runs up to normal running speed.
2. Rotate vice latches anticlockwise to open door (1 with key provided).
3. Place articles within the cabinet.
4. Close the door and engage all of the vice latches (1 with key provided).
5. Fit evidence seal/tag.
6. Note case reference on the white note board on door using a dry marker.
7. Keep the unit permanently switched **ON** when storing articles in the cabinet.
8. Use the hand shower to wash down the inside of the cabinet after it has been emptied or as and when necessary. (Please also refer to note 3 of 'Cleaning' on page 11.)
9. Fill in the **SAFELAB** Operational Safety Log Book after use.



WIRING DIAGRAM

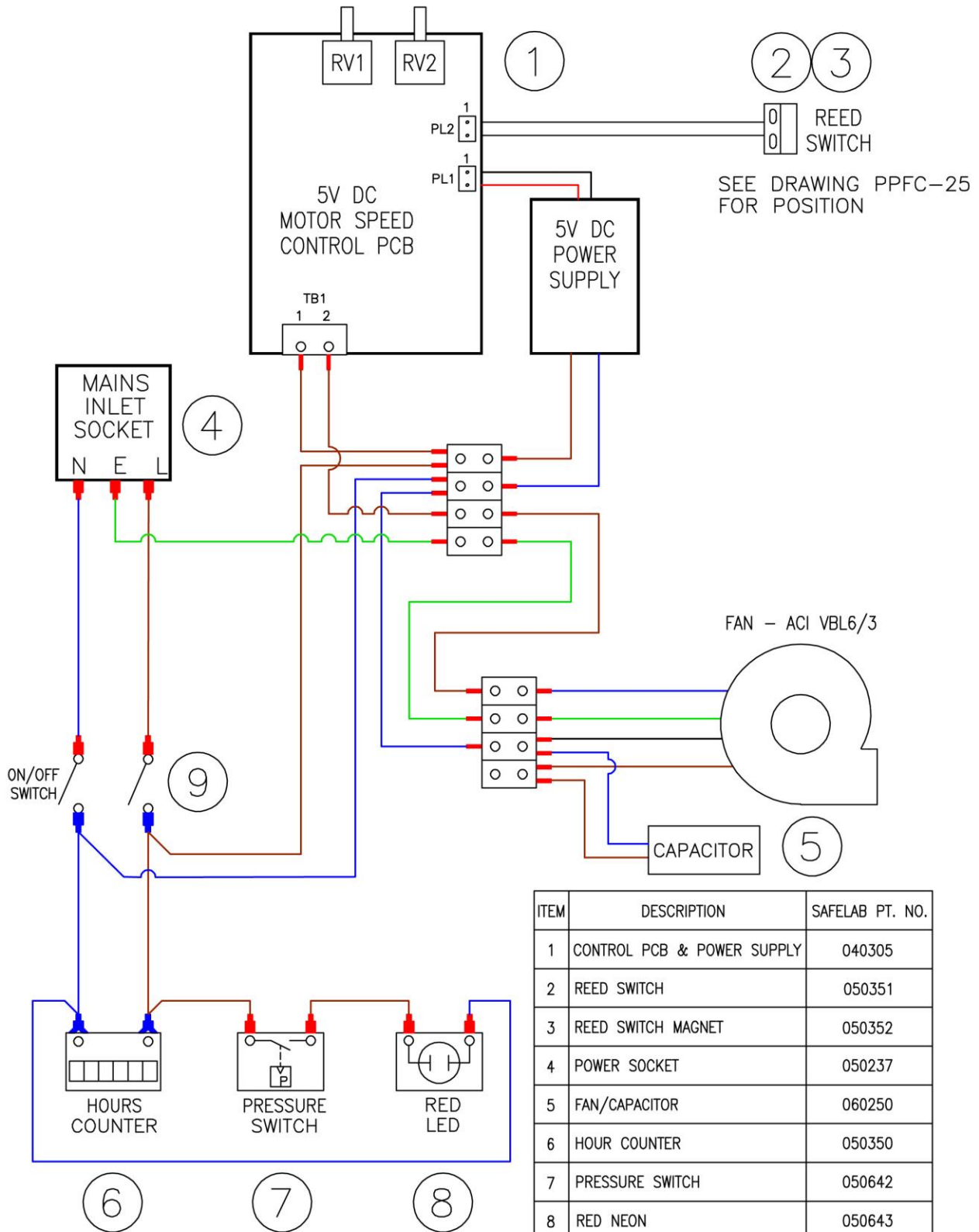

SEE DRAWING PPFC-25 FOR POSITION

| ITEM | DESCRIPTION | SAFELAB PT. NO. |
|------|----------------------------|-----------------|
| 1 | CONTROL PCB & POWER SUPPLY | 040305 |
| 2 | REED SWITCH | 050351 |
| 3 | REED SWITCH MAGNET | 050352 |
| 4 | POWER SOCKET | 050237 |
| 5 | FAN/CAPACITOR | 060250 |
| 6 | HOUR COUNTER | 050350 |
| 7 | PRESSURE SWITCH | 050642 |
| 8 | RED NEON | 050643 |
| 9 | ON/OFF SWITCH | 050245 |



CALIBRATION

(SHOULD ONLY BE UNDERTAKEN BY A SUITABLY QUALIFIED PERSON)

1. Remove four screws and withdraw the electrical panel at front right hand side of unit far enough to give access to the pressure switch adjuster screw and fan speed adjustment potentiometers RV1 & RV2 (see photo).

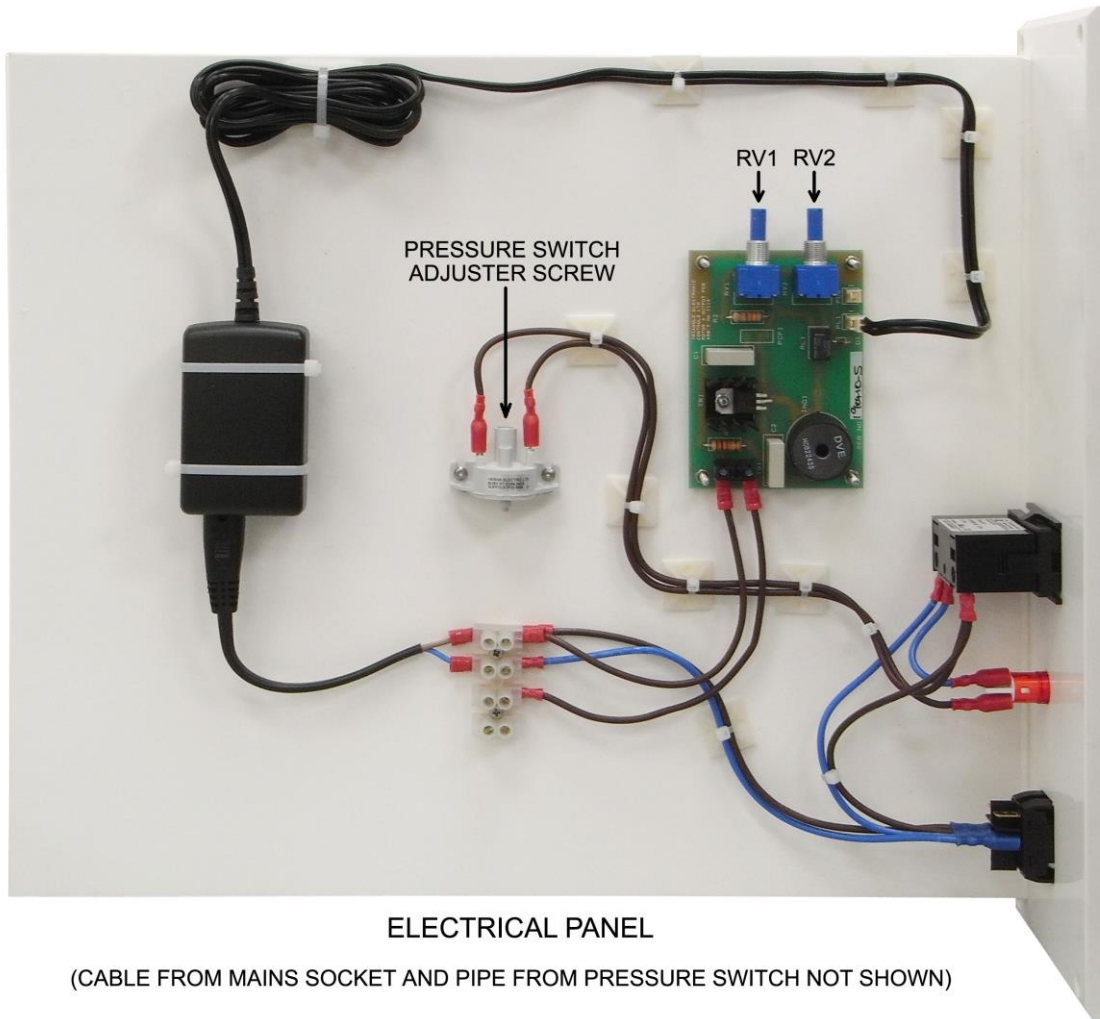

2. Switch on unit. Ensure door is shut. Measure airflow at pre-filter below cabinet door and adjust RV2 to obtain inlet airflow of 0.5m/s using a calibrated vane anemometer. Measure exhaust flow at top vent aperture.
3. Open the cabinet door, then adjust RV1 so that the airflow at the top exhaust vent is half of what it was with the door closed.
4. With the door open, cover pre-filter panel at the top inside of the cupboard just below the main filter. Close the door. If the red warning light comes on, rotate pressure switch adjuster screw anticlockwise until it goes out, then slowly rotate it clockwise until the red warning light just comes on.
5. Open the door and remove the cover from the pre-filter.
6. Refit the electrical panel.



MAINTENANCE

Your Polypropylene Forensic Drying Cabinet should have an annual service and inspection by a suitably qualified person, to maintain its good condition and reduce the possibility of hazard to the operator. We recommend that a service programme is arranged with **SAFELAB SYSTEMS LTD.**

Regular maintenance by our qualified personnel will ensure safe running of your equipment and will ensure that you meet your requirements under COSHH regulation 9.

CLEANING

1. The materials used to construct the Polypropylene Forensic Drying Cabinet have been selected to give maximum durability and a long life. It is beneficial however to regularly clean and decontaminate the internal and external surfaces.
2. It is recommended that the cabinet is switched on during any cleaning procedure and that suitable protective clothing (face-mask, gloves and safety glasses) are worn.
3. Surfaces, door and perforated stand should be cleaned with a mild detergent solution, followed by a clean water rinse and finished off with a damp cloth and wiped dry.



FILTER REPLACEMENT

DURING THE PRE-FILTER AND MAIN FILTER REPLACEMENT PROCEDURE, SUITABLE PROTECTIVE CLOTHING (FACE-MASK, GLOVES AND SAFETY GLASSES) MUST BE WORN

BOX PRE-FILTER REPLACEMENT

1. With the cabinet switched on, remove the panel that retains the box pre-filter by removing the 8 countersunk screws.
2. Remove the old filter, then place and seal it directly into a plastic bag for disposal.
3. Place the new filter in the recess and replace the retaining panel.

PRE-FILTER REPLACEMENT

1. With the cabinet switched on, open the front door.
2. Remove all items from the top hanging rail, then lift and remove the hanging rail. All hazardous substances should be removed from the cabinet and stored in a suitable place during the replacement procedure.
3. From inside the cabinet at the top, rotate tag, drop down the pre-filter clamping frame a little and remove pre-filter by folding the front edge away from you so that it's folded in half, withdraw it, then place and seal it directly into a plastic bag for disposal.
5. Locate new pre-filter on the filter frame, raise into position and rotate the retaining tag to secure it in place.
6. Refit the hanging rail
7. Replace the contents of the cabinet and close the front door.

Continued on page 13



FILTER REPLACEMENT (CONTINUED)

DURING THE PRE-FILTER AND MAIN FILTER REPLACEMENT PROCEDURE, SUITABLE PROTECTIVE CLOTHING (FACE-MASK, GLOVES AND SAFETY GLASSES) MUST BE WORN

MAIN FILTER/S REPLACEMENT

1. Switch off the cabinet and disconnect it from the mains electricity supply.
2. Remove the main filter cover panel (eight countersunk screws) to expose the main filter housing.
3. Unscrew the four knurled knobs inside the main filter housing that clamp the fan and plenum assembly on top of the filter. Four springs lift the assembly clear of the main filter as these are released.
4. Unpack the Main filter and prepare suitable equipment for its safe handling. Place the filter gasket side upwards on a clean flat surface (Retain the packaging for disposing of the old filter).
5. **Before removing the main filter please note it weighs approx. 15kg and may require two people to safely remove it from the housing.**
Firmly grip each side of the main filter, push up to break seal, and withdraw it from the filter housing.
6. Use the packaging that was retained from the new filter to place over the old filter for safe disposal.
7. With the gasket side downwards, slide the new filter into place between the guides in the main filter housing ensuring that it's located fully to the back stop and evenly retighten the four knurled knobs to clamp the fan and filter assembly above the main filter. Lower pre-filter panel and inspect gasket seating of the main filter.
8. Fill in the date on the filter identification label and stick it on the front of the filter ensuring it will be clearly visible through the window in the front of the access panel.
9. Replace the main filter front cover panel.
10. Reconnect to the mains electricity supply and switch on the cabinet.
11. Enter details of main filter change in the Safety Log Book.
12. Following this procedure it is recommended that the filter monitoring procedure detailed in the Operational Safety Manual is performed. This ensures correct seating of the filter within the cabinet.
Written records of filter monitoring are a legal requirement under COSHH.



SPARE PARTS

| | |
|-----------------|--|
| Main Filter: | See identification label on front of filter. |
| Box pre-filter. | Part No. 111949 (1.0 metre cabinet) Part No. 111950 (1.2 metre cabinet) |
| Pre-filter: | Part No. 111088 (pack of 12) |
| Key: | Part No. 130206 |
| Mains lead: | Part No. 050201 |



Safelab Systems Ltd

**Airone Building
8 Beaufighter Road
Weston-Super-Mare
BS24 8EE**

Tel: + 44 (0) 1934 421 340

Fax: + 44 (0) 1934 641 569

E-mail address: safelab@safelab.co.uk

www.safelab.co.uk



E.C. DECLARATION OF CONFORMITY

Safelab Systems Ltd

hereby certify that the

FSC 1000 Forensic Drying Cabinet

Conforms to the requirements of the
Low Voltage Directive #73/23/EEC and the
Electromagnetic Compatibility Directives # 89/336/EEC and #92/31/EEC

Complying with the conformity criteria of European Standards:

EN 61010-1: 1993 safety requirements for electrical equipment for measurement, control and
laboratory use Part 1 : General requirements

EN 50081-1, EN 50082-1 : Emission Limits to Reference Standards:

EN 60555-2 & 3, EN 55022/B, EN 55014

Signed:

Roger Guess, Manager Director
Safelab Systems Ltd

Dated: 1st November 2015

The single source for the complete clean air solution

Registered No: 5336826 England and Wales
Registered Office: Airone Building, 8 Beaufighter Road, Weston-Super-Mare BS24 8EE

DOCUMENT NO: P54 ISSUE NO: 06 CREATED: 01/11/2015